

家庭储能系统 HOME ENERGY STORAGE SYSTEM

PB-5KWH

INTRODUCE 简介

A lithium battery pack for home energy storage systems, which is compatible with solar panels and the sun. The inverter can work together with the power grid to power household appliances, and it can also be used as a For off grid systems, such as microgrid power plants.

家庭储能系统锂电池组,它与太阳能电池板、太阳能逆变器和电网一起为家用电器供电,同时它也可作为离网系统,如微网电站。

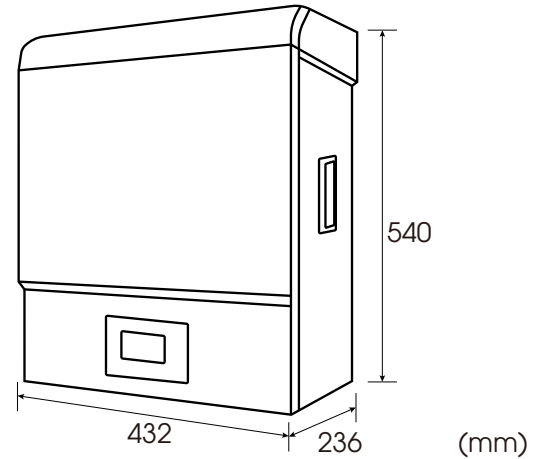

FEATURES & BENEFITS 功能和优点

- ◆ **Lithium iron phosphate battery, safe and environmentally friendly**
磷酸铁锂电池,安全环保
- ◆ **With over-current, over-voltage, under-voltage, short-circuit, over-temperature protection functions**
具有过流、过压、欠压、短路、过温保护功能
- ◆ **With high-precision voltage, current, and temperature detection for automatic charging or disconnecting loads**
具有高精度电压、电流、温度检测自动充电或断开负载
- ◆ **Continuous discharge up to 1.1C**
持续可达1.1C放电
- ◆ **When the system is in a non working state, it has standby sleep mode and maintains a low consumption state**
当系统处于非工作状态时,具有待机休眠模式,保持低消耗状态
- ◆ **With equalization function**
带均衡功能
- ◆ **Modular design, wall mounted installation**
模块化设计,壁挂式安装
- ◆ **Off-grid operation and grid-connected operation**
可离网运行,可并网运行
- ◆ **Support 3-8 products to be used in parallel**
支持3-8台产品并联使用
- ◆ **IP65 protection grade**
防护等级IP65

APPLICATION SCENARIO 应用场景

- ◆ **Family**
家庭
- ◆ **Industrial business district**
工业商业区
- ◆ **Solar energy storage system**
太阳能储能系统
- ◆ **Farm**
农场
- ◆ **Remote suburbs**
偏远郊区
- ◆ **Wind Energy Storage System**
风能储能系统

SPECIFICATIONS 规格

MODEL:PB-5KWh

Rated energy (KWh) 额定能量	5.12 KWh
Rated voltage (V) 额定电压	51.2 V
Rated Capacity (Ah) 额定容量	100 Ah
Voltage range (V) 电压范围	40-58.4 V
Charge and discharge current (A) 充放电电流	100 A
Working temperature 工作环境温度	-20-60°C
Cycle 循环	4000 times (次) , 80%DOD, 25°C
Discharge 放电	85%DOD, can be set (可设置)
Weight (kg) 重量	50 kg
Communication 通讯	RS485, RS232, CAN
Protective function 保护功能	Overcurrent, Overvoltage, Undervoltage, Short circuit, Overtemperature 过流、过压、欠压、短路、过温
Installation method 安装方式	Wall hanging 壁挂

APPEARANCE SPECIFICATION 外观规格

Dimension(L x W x H mm) 尺寸(长 x 宽 x 高 mm)	540 x 432 x 236 mm
---	--------------------

System function link 系统功能链接

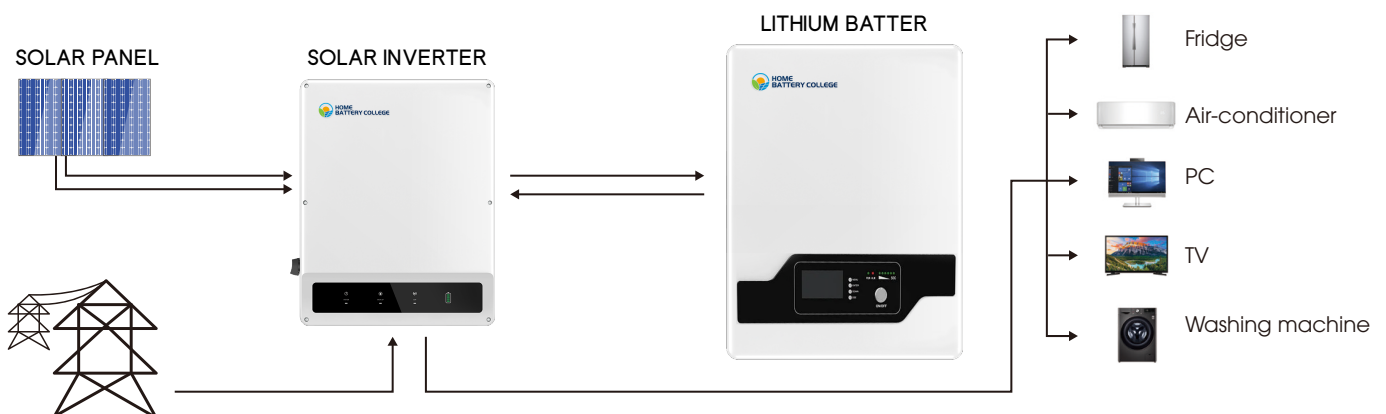

BATTERY CHARACTERISTICS 电池特性

◆ Different current/Temperature Discharge curves

不同的电流 / 温度放电曲线

Different Rate Discharge Curve @25°C

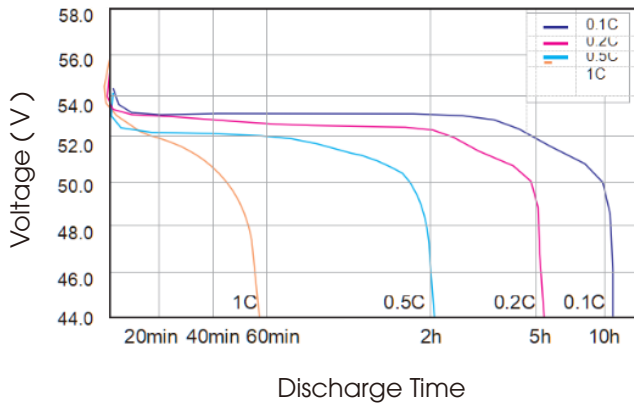

Different Temperature Discharge Curve @0.5C

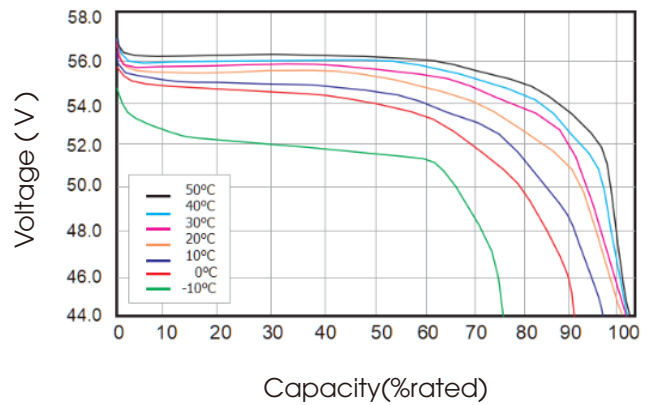

◆ Charging and Discharge curve

充放电曲线

Charge and Discharge at 25°C,0.5C

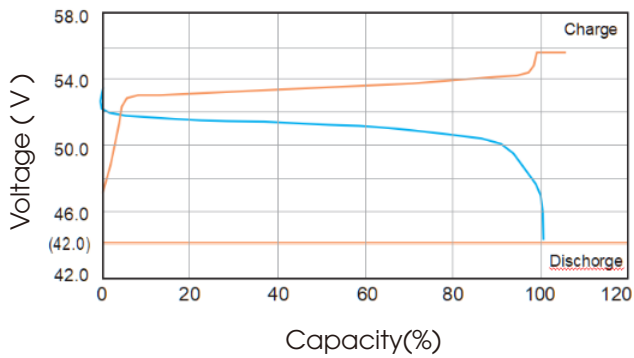

Different Temperature Self Discharge Curve

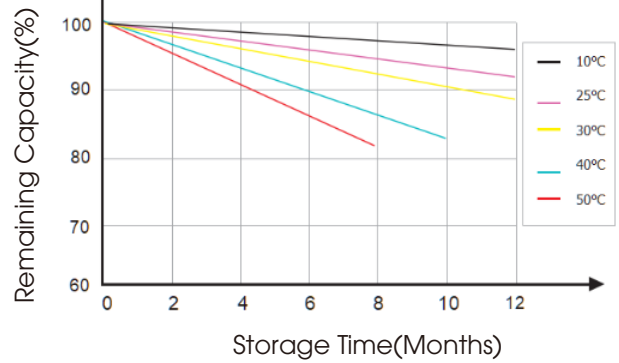

◆ Cycle Life Curve

循环寿命曲线

Different Discharge Depth Life Curves & 25°C,0.5C

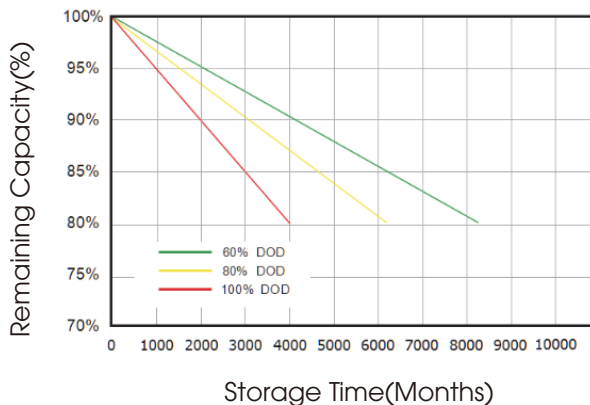

Different Discharge Depth Life Curves & 40°C,0.5C

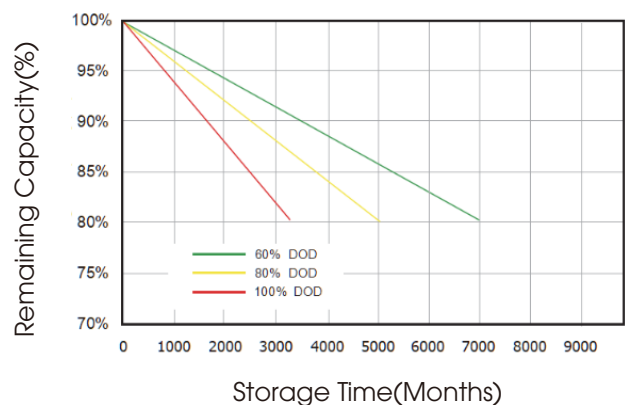

AUTHENTICATION 认证



MSDS



CERTIFIED
UL 1973
UL 9540A

STORAGE 储存

- ◆ Avoid storing in high or low temperature environments, preferably between 15°C and 25°C.
避免存放在高温或低温环境中, 温度最好在 15°C~25°C 之间。
- ◆ When storing, it is important to avoid external vibrations and collisions as much as possible to avoid short circuits inside the battery or damage to the metal casing.
存放时应尽量避免外力的振动和碰撞, 以免造成电池内部短路或损坏金属外壳。
- ◆ It should be stored in a dry and ventilated place, away from sources of ignition, direct sunlight, and humidity. Moisture-proof preservatives or desiccants can be used.
需存放在干燥通风的地方, 远离火源、日光直射和潮湿, 可以使用防潮保鲜剂或干燥剂。

TRANSPORT 运输

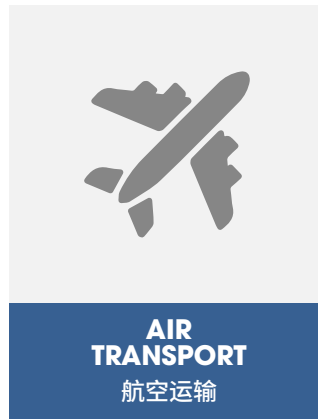
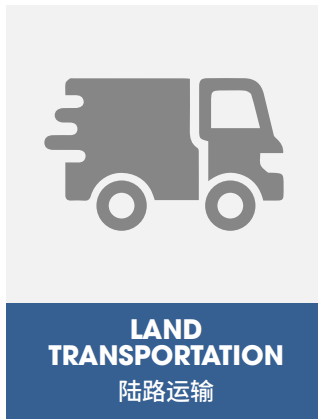

CONTACT INFORMATION 联系方式

◆ **From:** ESS COLLEGE
公司: ESSC

◆ **Tel:** +86-18512006111
电话: +86-18512006111

◆ **Add:** ShangYan Road ,YuanZhou Ave.,YuanZhou Town,HuiZhou City,
GuangDong Province,P.R.C

地址: 广东省惠州市袁州镇袁州大道上燕路