

TOWER BACKUP BATTERY SYSTEM 48200

铁塔后备电池系统

introduction 简介

The 48V series Lithium iron phosphate battery has the communication function and can realize multiple groups of parallel connection, providing flexible and effective solutions for the power system of communication operators.

48V系列磷酸铁锂电池具有通信功能,可实现多组并联,为通信运营商的电源系统提供灵活有效的解决方案。

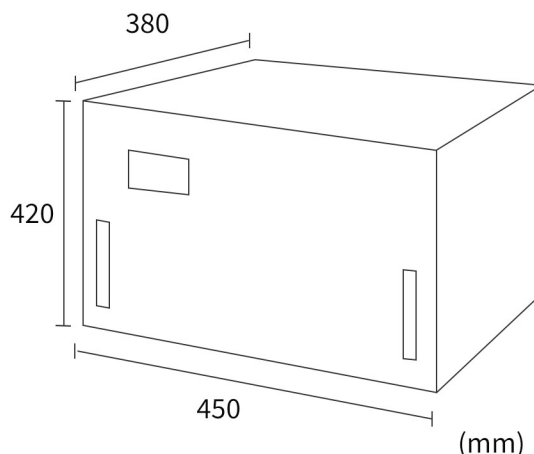

FEATURES & BENEFITS 功能和优点

- ◆ **Improve communication continuity**
提高通信连续性
- ◆ **Reduce energy consumption**
降低能源消耗
- ◆ **Provide standing power**
提供常备电力
- ◆ **Emergency backup power**
应急备用电力
- ◆ **Energy storage**
储能
- ◆ **Improve security**
提高安全性
- ◆ **High stability**
稳定性高
- ◆ **Economical and practical**
经济实用

APPLICATION SCENARIO 应用场景

- ◆ **When the power grid is cut off**
电网停电时
- ◆ **Emergency situations such as natural disasters**
自然灾害等紧急情况
- ◆ **Emergency situations**
紧急应急场合
- ◆ **Energy reserve**
能量储备

Product Technical Specifications

产品技术规格

Product model 产品型号	48200
Basic parameters of battery cells 电芯基本参数	
Individual voltage 单体电压	3.2V
Nameplate capacity 额定容量	5.0 Ah
Voltage range 电压范围	2.5-3.65V
Operating temperature range 使用温度范围	- 25°C~65°C
Basic parameters of battery pack 电池包基本参数	
voltage 电压	51.2V
capacity 容量	200Ah
energy 能量	10240Wh
Dimensions (length * width * height) 尺寸(长*宽*高)	450*380*420mm
weight 重量	185kg
Electrical characteristics 电气特性	
Battery pack voltage range 电池包电压范围	40~58.4V
Maximum charging current 最大充电电流	100A
Maximum discharge current 最大放电电流	100A
Charging efficiency 充电效率	98%
Charging conversion efficiency 充电转换效率	96%
Communication method 通讯方式	RS485/RS232
working temperature 工作温度	
Charging temperature 充电温度	0°C~60°C
Discharge temperature 放电温度	- 20°C~60°C
Storage temperature 存储温度	5°C~45°C
Protection level 防护等级	Ip20

Battery characteristics 电池特性

Charge discharge cycle life curve

充放电循环寿命曲线

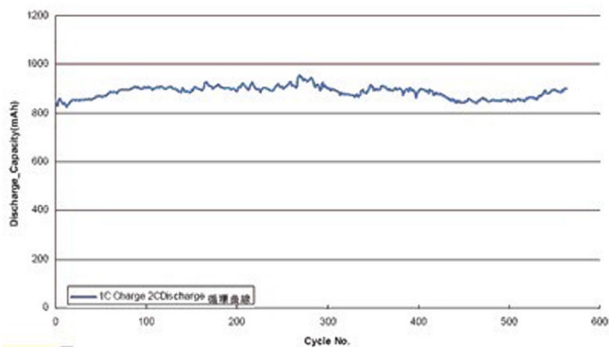

充放电循环寿命曲线

Discharge characteristics

放电特性

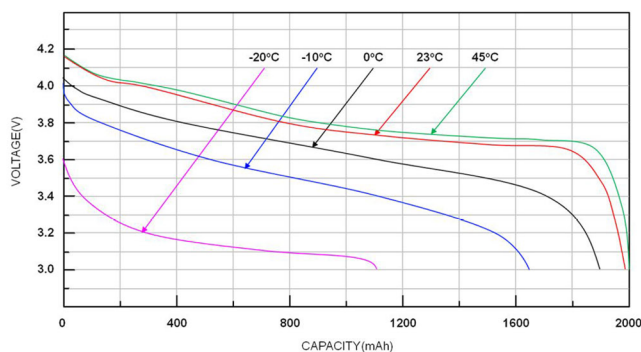

Indirect power supply curve diagram

间接式供电曲线图

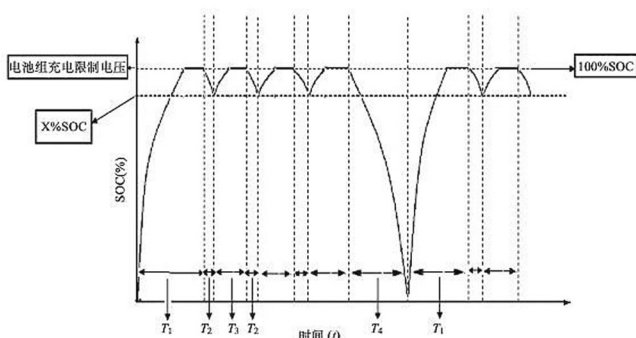

间接式的供电曲线图

Discharge voltage at different temperatures

不同温度放电电压

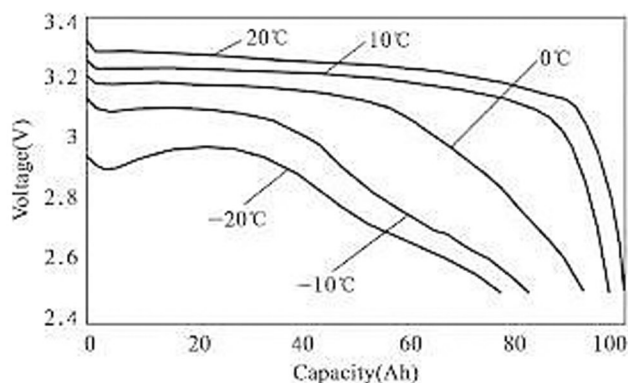

不同温度放电电压

Constant current discharge voltage vs battery capacity

恒流放电电压vs电池容量

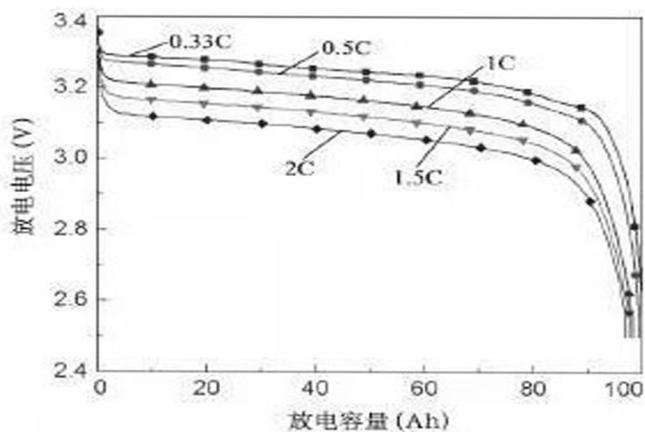

(a) 20°C下恒流放电电压 vs 电池容量

Ratio vs constant current discharge capacity

倍率vs恒流放电容量

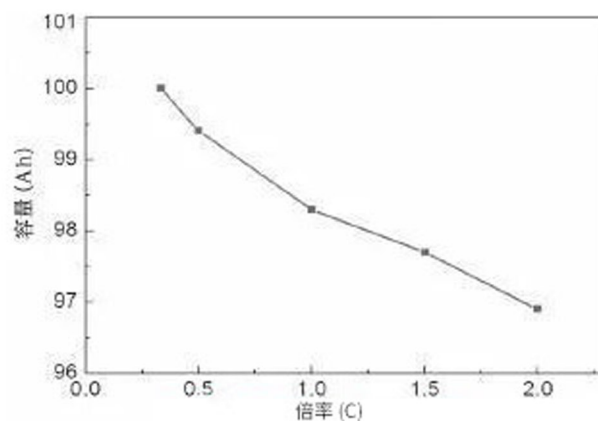

(b) 20°C下倍率vs恒流放电容量

Authentication 认证



MSDS



Storage 储存

Avoid storing in high or any temperature environment, with a temperature range between 15C and 25C

When storing, it is important to avoid external vibrations and collisions as much as possible to avoid internal short circuits or damage to the metal casing of the battery.

Store in a dry and ventilated place, away from sources of ignition, direct sunlight, and moisture. Use moisture-resistant preservatives or desiccants

Provide multiple packaging methods, which can be selected based on the product. 10-15 days (conventional transportation method)

避免存放在高温或任温环境中,温度景好在15C~25C之间

存放时应尽量避免外力的振动和碰撞,以免造成电池内部短路或损坏金外壳。

需存放在干燥通风的地方,远离火源、日光直射和潮湿,可以使用防潮保鲜剂或干燥剂

transport 运输

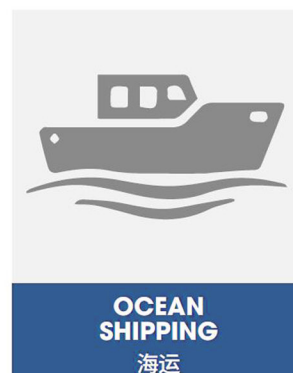
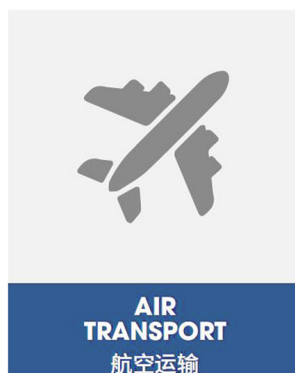
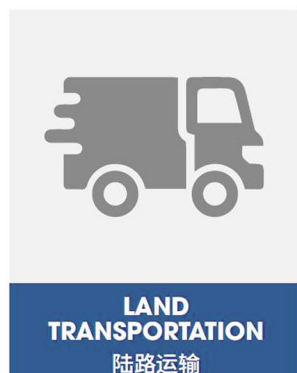

CONTACT INFORMATION 联系方式

◆ **From:** ESS COLLEGE
公司:ESSC

◆ **Tel:** +86-18512006111
电话: +86-18512006111

◆ **Add:** ShangYan Road ,YuanZhou Ave.,YuanZhou Town,HuiZhou City,
GuangDong Province,P.R.C

地址:广东省惠州市袁州镇袁州大道上燕路