

## CARSHARING SERIES

Q5

共享车系列

### introduction 简介

Electric vehicle battery is the core part, which determines its endurance, performance and life. With the continuous improvement of the performance of Electric vehicle battery, it provides strong support for the development of electric vehicles.

电动车电池是核心部分，决定了它的续航能力、性能和寿命。随着电动车电池的性能不断提升，为电动汽车的发展提供了强有力的支持。

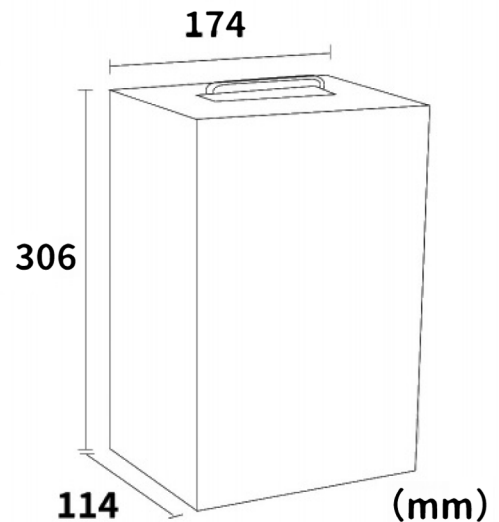

### FEATURES & BENEFITS 功能和优点

- ◆ **Converting electrical energy into current**  
电能转化为电流
- ◆ **Reduce pollution, efficient environmentally friendly**  
降低污染，高效环保
- ◆ **Reduce weight and improve utilization**  
减少重量，提高利用率
- ◆ **Low noise, smooth driving**  
噪音较小，行驶平稳
- ◆ **rechargeable**  
可充电
- ◆ **Provide power**  
提供动力
- ◆ **High endurance**  
续航能力高
- ◆ **Storage of electrical energy**  
储存电能

### APPLICATION SCENARIO 应用场景

- ◆ **Electric bicycles**  
电动自行车
- ◆ **Light electric vehicles**  
轻型电动汽车
- ◆ **Motorcycles**  
摩托车
- ◆ **Heavy electric truck**  
重型电动卡车

## Product Technical Specifications 产品技术规格

model 型号	Q5
Shell material 壳体材质	SPCC
Size (mm) 尺寸(mm)	306*174*114
weight 重量	8.3kg
Cell model 电芯型号	26700
Rated voltage (V) 额定电压(V)	48
Rated current (Ah) 额定电流(Ah)	20
Continuous discharge current (A) 持续放电电流(A)	20

## Protection board function 保护板功能

project 项目	parameter 参数	Remarks 备注
Charging protection voltage 充电保护电压	4.25V	Monomer 单体
Overcharge recovery voltage 过充恢复电压	4.15V	Monomer 单体
Discharge protection voltage 放电保护电压	2.75V	Monomer 单体
Overdischarge recovery voltage 过放恢复电压	3.0V	Monomer 单体
Overcurrent protection 过流保护	20±10A	IC
Short circuit protection 短路保护	have 有	IC

## Battery characteristics 电池特性

The relationship between voltage and capacity under different discharge rates and temperatures

不同放电率、温度下电压与容量的关系

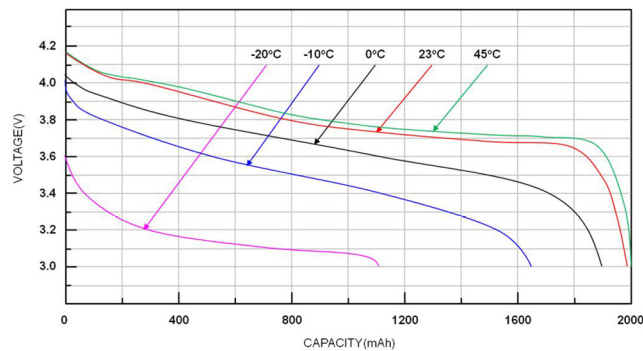
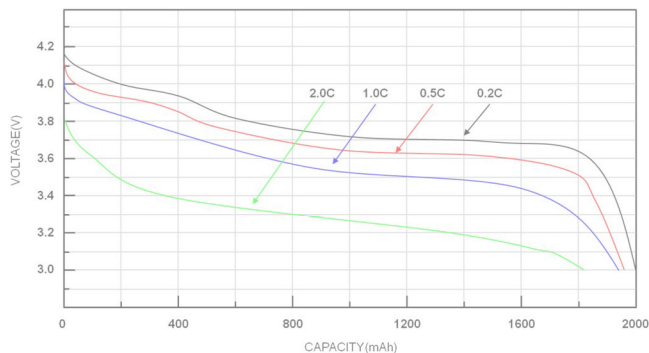
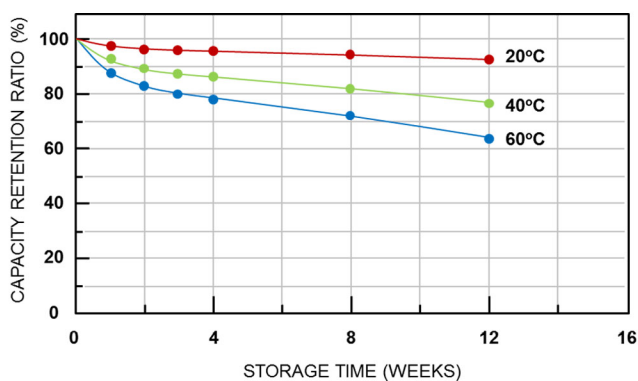
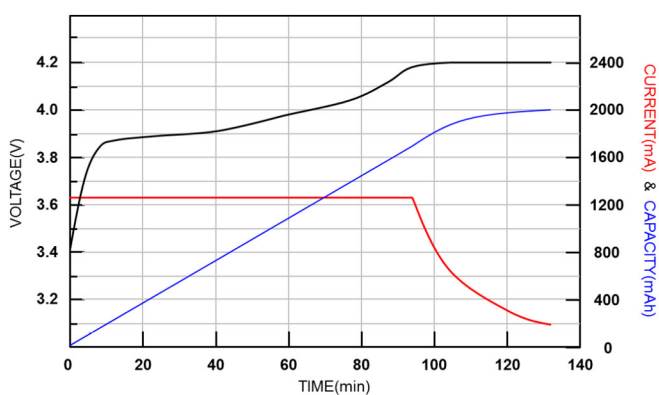

Figure 1: Charging characteristics

图1: 充电特性

Figure 2: Self discharge rate at different temperatures

图2: 不同温度的自放电率



The relationship between the number of cycles and battery capacity

循环次数与电池容量的关系

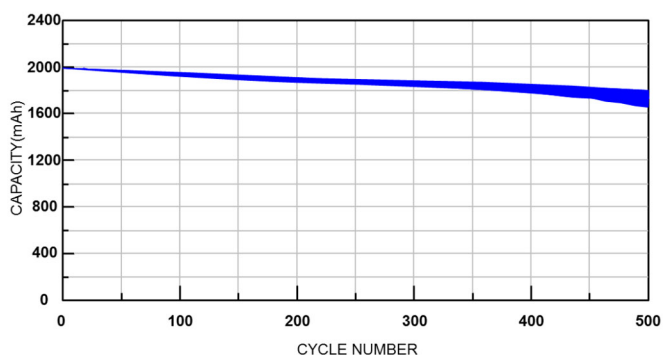

## Authentication 认证



MSDS



## Storage 储存

Avoid storing in high or any temperature environment, with a temperature range between 15C and 25C

When storing, it is important to avoid external vibrations and collisions as much as possible to avoid internal short circuits or damage to the metal casing of the battery. Store in a dry and ventilated place, away from sources of ignition, direct sunlight, and moisture. Use moisture-resistant preservatives or desiccants

Provide multiple packaging methods, which can be selected based on the product. 10-15 days (conventional transportation method)

避免存放在高温或任温环境中,温度景好在15C~25C之间

存放时应尽量避免外力的振动和碰撞,以免造成电池内部短路或损坏金外壳。

需存放在干燥通风的地方,远离火源、日光直射和潮湿,可以使用防潮保鲜剂或干燥剂

## transport 运输

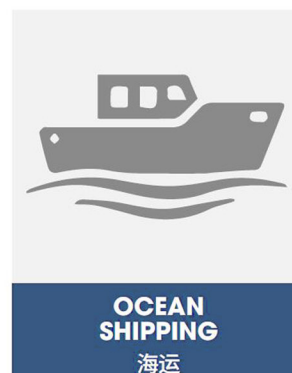
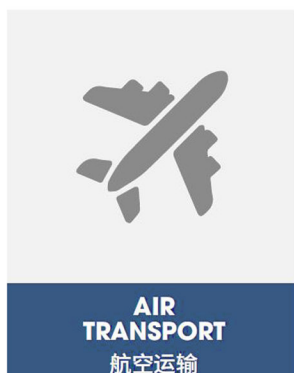
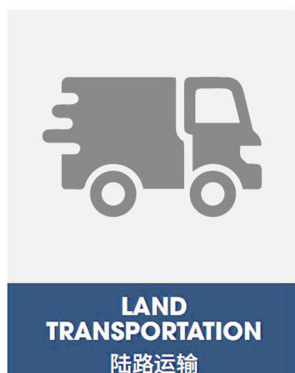

## CONTACT INFORMATION 联系方式

◆ **From:** ESS COLLEGE  
公司:ESSC

◆ **Tel:** +86-18512006111  
电话: +86-18512006111

◆ **Add:** ShangYan Road ,YuanZhou Ave.,YuanZhou Town,HuiZhou City,  
GuangDong Province,P.R.C

地址:广东省惠州市袁州镇袁州大道上燕路