

INTRODUCE

简介

A lithium battery pack for home energy storage systems, which is compatible with solar panels and the sun. The inverter can work together with the power grid to power household appliances, and it can also be used as a For off grid systems, such as microgrid power plants.

家庭储能系统锂电池组,它与太阳能电池板、太阳能逆变器和电网一起为家用电器供电,同时它也可作为离网系统,如微网电站。

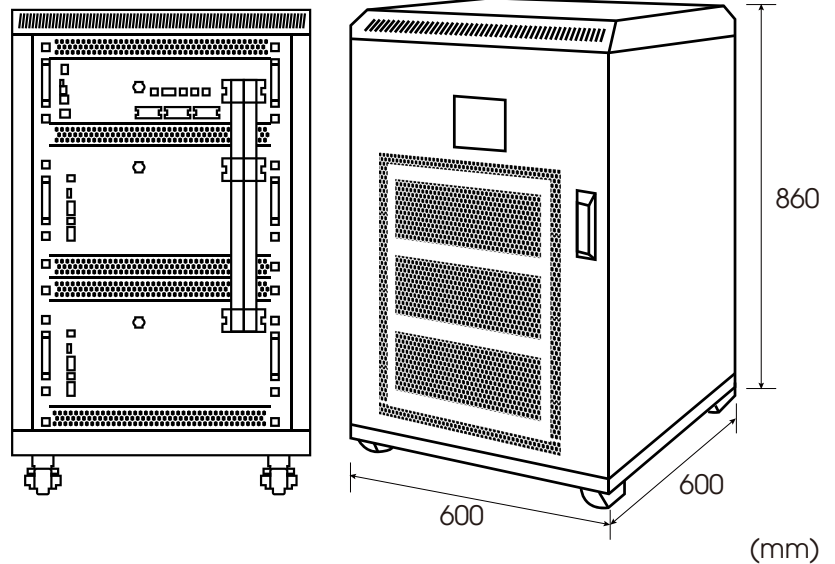

FEATURES & BENEFITS 功能和优点

- ◆ **Lithium iron phosphate battery, safe and environmentally friendly**
磷酸铁锂电池,安全环保
- ◆ **With over-current, over-voltage, under-voltage, short-circuit, over-temperature protection functions**
具有过流、过压、欠压、短路、过温保护功能
- ◆ **With high-precision voltage, current, and temperature detection for automatic charging or disconnecting loads**
具有高精度电压、电流、温度检测自动充电或断开负载
- ◆ **When the system is in a non working state, it has standby sleep mode and maintains a low consumption state**
当系统处于非工作状态时,具有待机休眠模式,保持低消耗状态
- ◆ **With equalization function**
带均衡功能
- ◆ **Modular design**
模块化设计
- ◆ **Off-grid operation and grid-connected operation**
可离网运行,可并网运行
- ◆ **IP40 protection grade**
防护等级IP40

APPLICATION SCENARIO 应用场景

- ◆ **Family**
家庭
- ◆ **Farm**
农场
- ◆ **Factory**
工厂
- ◆ **Industrial business district**
工业商业区
- ◆ **Remote suburbs**
偏远郊区
- ◆ **Solar energy storage system**
太阳能储能系统
- ◆ **Wind Energy Storage System**
风能储能系统

SPECIFICATIONS 规格

MODEL:5KW10.4KWh

SYSTEM PARAMETERS 系统参数

Maximum input power 最大输入功率	5 KW
Maximum output power 最大输出功率	5 KW
System capacity 系统容量	10.4 KWh
Battery Type 电池类型	LiFePO4
Degree of protection 防护等级	IP40
Maximum number of batteries connected in parallel 最大并联电池数量	2
Weight 重量	180 Kg
Life 寿命	≥ 5000 cycles (循环), 10 years (年)

ADAPT INVERTER PARAMETERS 适配逆变器参数

Maximum charging power 最大充电功率	5 KW
Maximum output power 最大输出功率	5 KW
DC input voltage range 直流输入电压范围	40V~60V
DC output voltage range 直流输出电压范围	40V~58V
Phase 相数	Simplex (单相)
Rated AC input voltage 额定交流输入电压	220 V
Rated AC output voltage 额定交流输出电压	220 V
Rated frequency 额定频率	50/60 Hz

BATTERY TECHNICAL PARAMETERS 电池技术参数

Battery rated capacity 电池额定容量	200 Ah
Battery rated voltage 电池额定电压	51.2 V
Battery working voltage 电池工作电压	40V~58.4V
Communication interface 通讯界面	CAN/RS232/RS485
Continuous charging current 持续充电电流	100A
Continuous discharge current 持续放电电流	100A
Peak charge current 峰值充电电流	100A
Peak discharge current 峰值放电电流	100A
Cooling method 冷却方式	Natural Cooling (自然冷却)
Waterproof level 防水等级	IP40
Charging temperature 充电温度	0°C ~ 60°C
Discharge temperature 放电温度	-20°C ~ 60°C

APPEARANCE SPECIFICATION 外观规格

Dimension(L x W x H mm) 尺寸(长 x 宽 x 高 mm)	600 x 600 x 860 mm
---	--------------------

SYSTEM FUNCTION LINK 系统功能链接

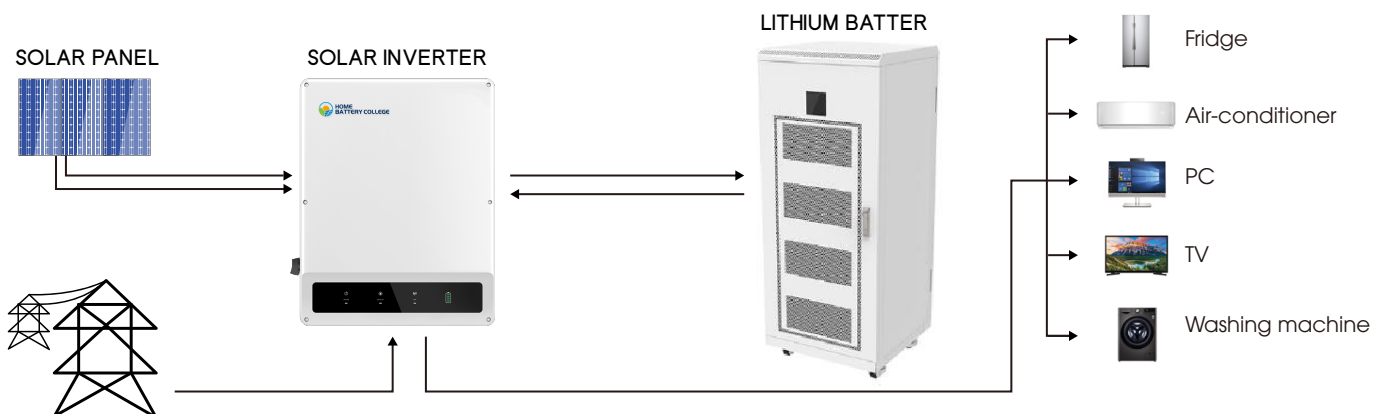

BATTERY CHARACTERISTICS 电池特性

◆ Different current/Temperature Discharge curves

不同的电流 / 温度放电曲线

Different Rate Discharge Curve @25°C

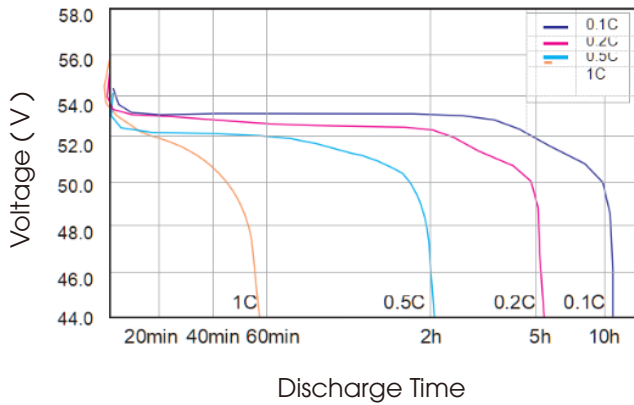

Different Temperature Discharge Curve @0.5C

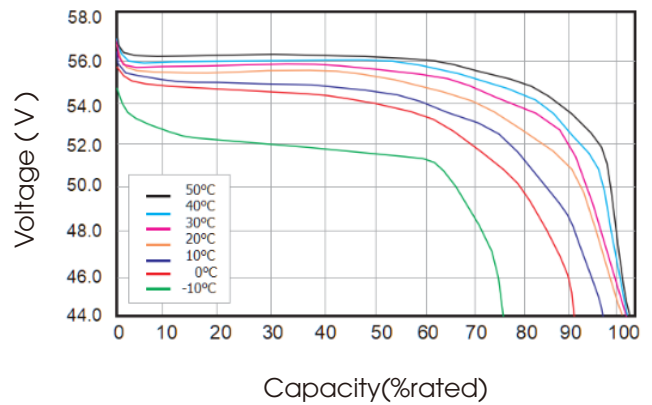

◆ Charging and Discharge curve

充放电曲线

Charge and Discharge at 25°C,0.5C

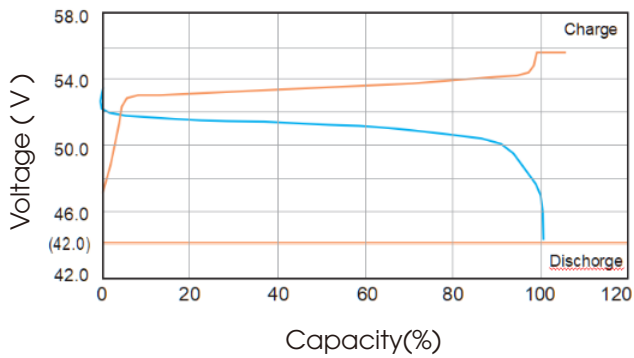

Different Temperature Self Discharge Curve

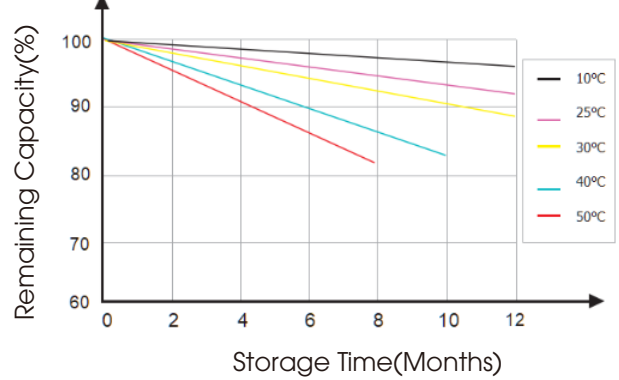

◆ Cycle Life Curve

循环寿命曲线

Different Discharge Depth Life Curves & 25°C,0.5C

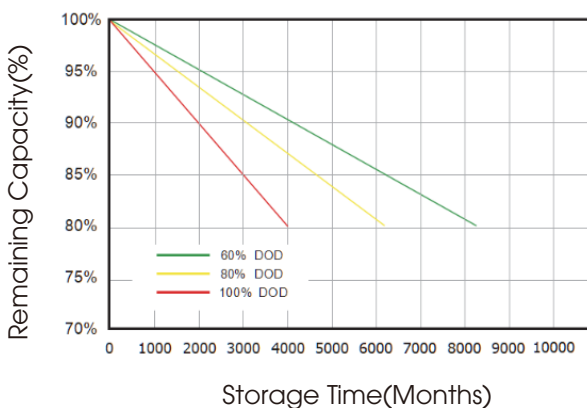

Different Discharge Depth Life Curves & 40°C,0.5C

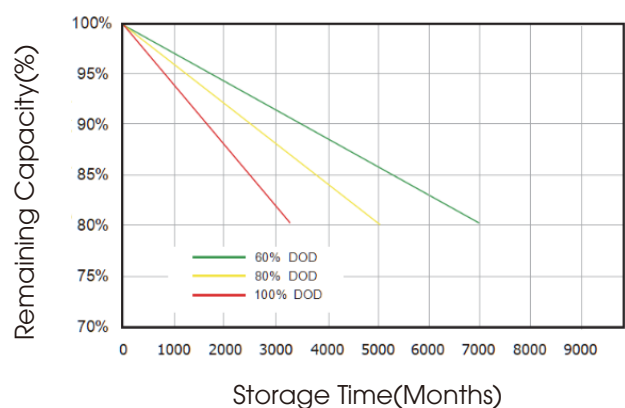

AUTHENTICATION 认证



MSDS



CERTIFIED
UL 1973
UL 9540A

STORAGE 储存

- ◆ Avoid storing in high or low temperature environments, preferably between 15°C and 25°C.
避免存放在高温或低温环境中, 温度最好在 15°C~25°C 之间。
- ◆ When storing, it is important to avoid external vibrations and collisions as much as possible to avoid short circuits inside the battery or damage to the metal casing.
存放时应尽量避免外力的振动和碰撞, 以免造成电池内部短路或损坏金属外壳。
- ◆ It should be stored in a dry and ventilated place, away from sources of ignition, direct sunlight, and humidity. Moisture-proof preservatives or desiccants can be used.
需存放在干燥通风的地方, 远离火源、日光直射和潮湿, 可以使用防潮保鲜剂或干燥剂。

TRANSPORT 运输

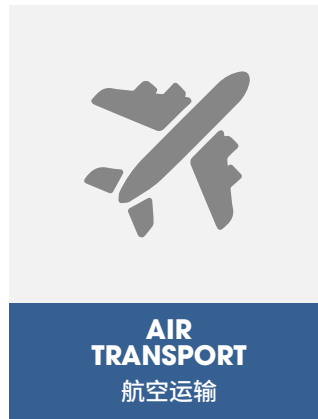
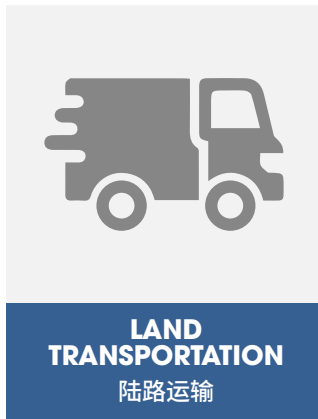

CONTACT INFORMATION 联系方式

◆ **From:** ESS COLLEGE
公司: ESSC

◆ **Tel:** +86-18512006111
电话: +86-18512006111

◆ **Add:** ShangYan Road ,YuanZhou Ave.,YuanZhou Town,HuiZhou City,
GuangDong Province,P.R.C

地址: 广东省惠州市袁州镇袁州大道上燕路